

# OIHA State Meet

## Western Showmanship

Show Date: \_\_\_\_\_

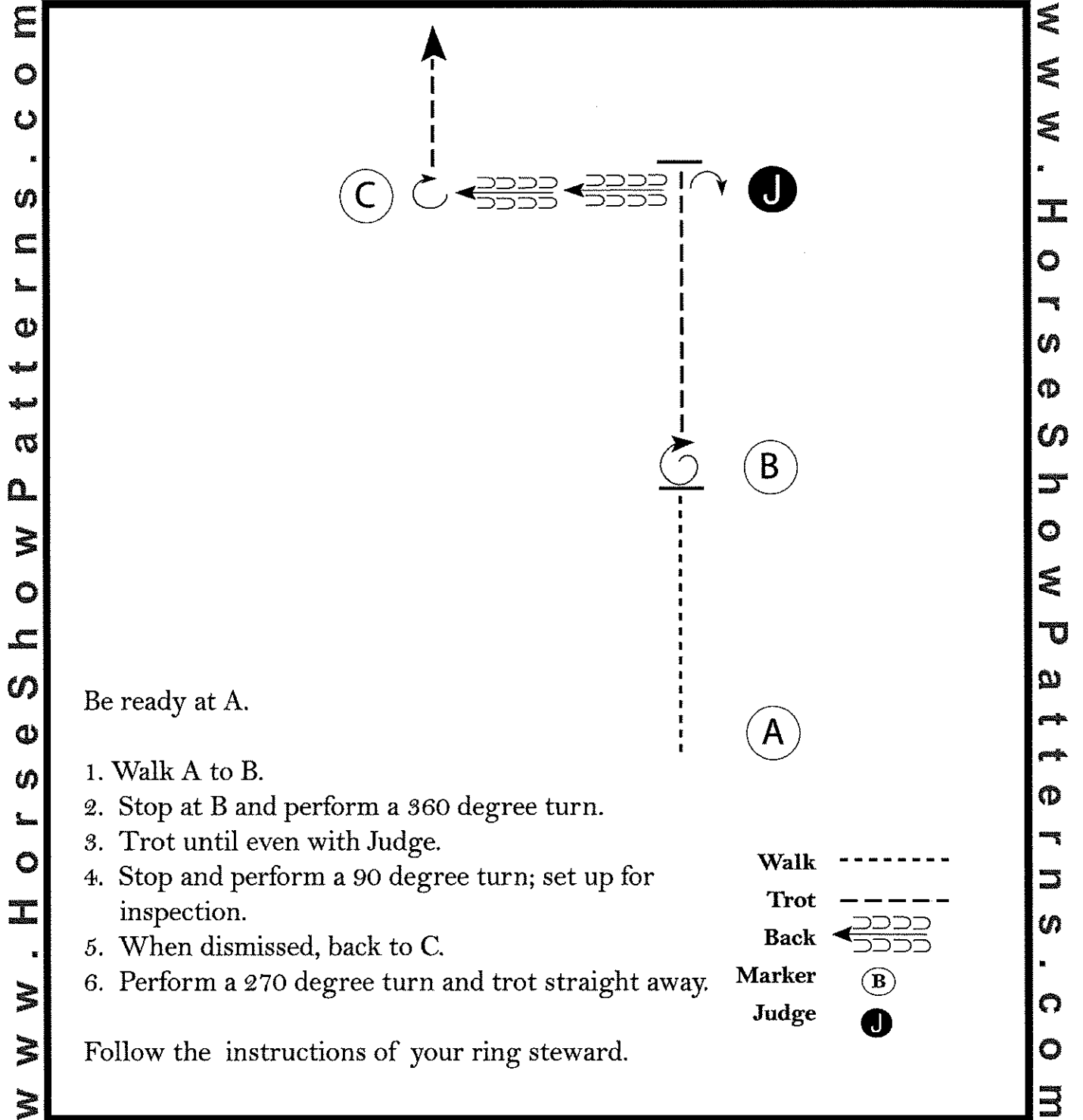

Be ready at A.

1. Walk A to B.
2. Stop at B and perform a 360 degree turn.
3. Trot until even with Judge.
4. Stop and perform a 90 degree turn; set up for inspection.
5. When dismissed, back to C.
6. Perform a 270 degree turn and trot straight away.

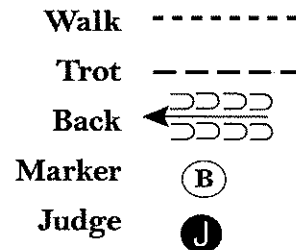

Follow the instructions of your ring steward.

[S/2-4]

Pattern Provided by:

OIHA Patterns Committee

# OIHA State Meet

## Hunt Seat Showmanship

Show Date:

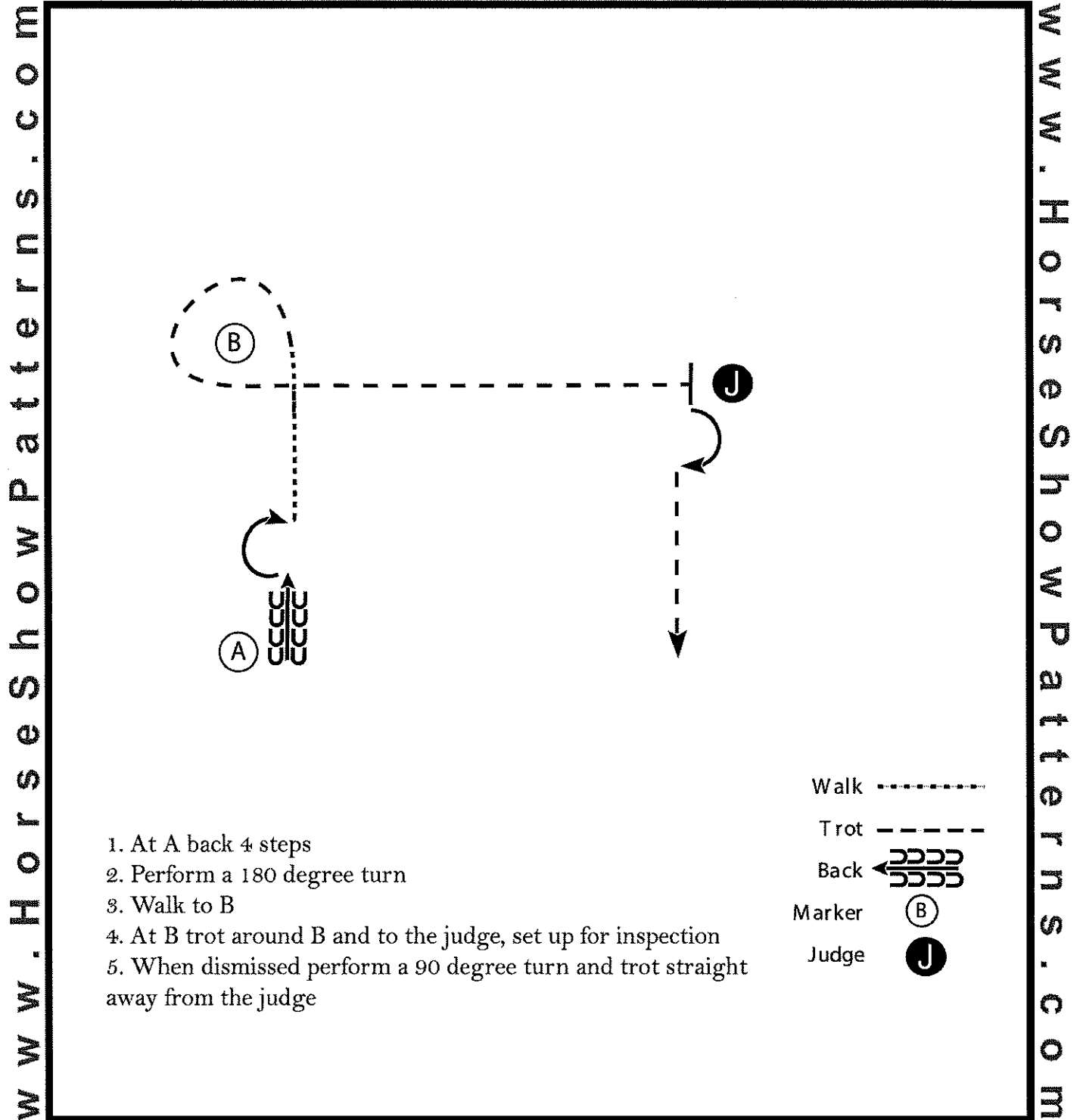

[S/2-1]

Pattern Provided by:

OIHA Patterns Committee

# OIHA State Meet

## Saddle Seat Showmanship

Show Date:

www.HorseShowPatterns.com

www.HorseShowPatterns.com

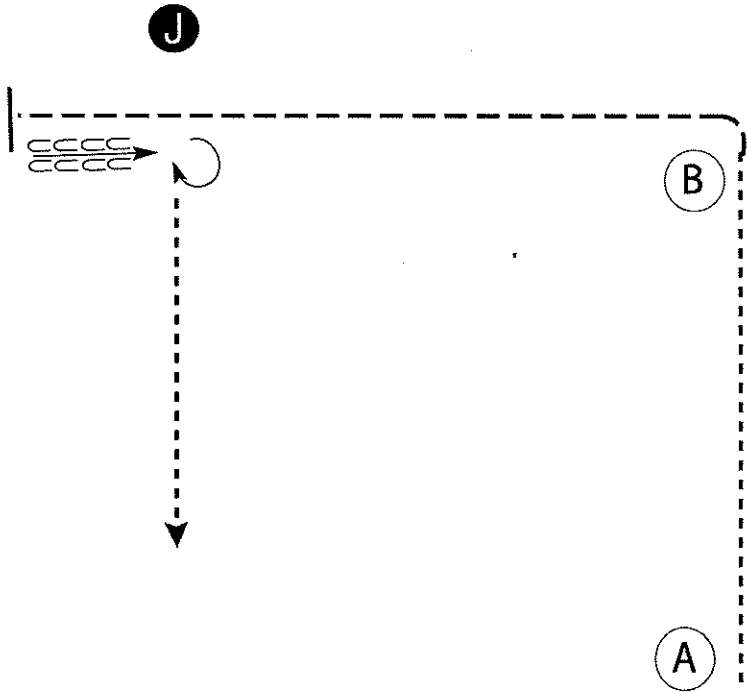

Be ready at A.

1. Walk to B.
2. Trot around B and past judge.
3. Stop past judge and back until hind end of horse is even with judge.
4. Turn 270 degrees and set up for inspection.
5. When dismissed, walk straight away from judge.

Walk	-----
Trot	-----
Back	← ↔ ↔
Marker	ⓑ
Judge	Ⓝ

[S/2-23]

Pattern Provided by:

OIHA Patterns Committee

# OIHA State Meet

## Saddle Seat Pattern



Show Date:

www.HorseShowPatterns.com

Begin at the in gate.

1. Trot the first half circle to the right on the right diagonal.
2. Trot the second half circle on the left diagonal.
3. Stop briefly in the center of the arena.
4. Canter the third half circle on the left lead.
5. Canter the fourth half circle on the right lead.
6. Go directly into the trot (B) in a clockwise direction along the rail and around curve (C).
7. Continue the trot in a diagonal line to the out gate (A) - diagonal is your option.

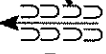
The workout has been completed - Thank You.

Walk - - - - -  
Trot - - - - -  
Extended Trot - - - - -  
Canter - - - - -  
Lead Change   
Back   
Reference Point 

www.HorseShowPatterns.com

[SSE/15]

Pattern Provided by:  
*OIHA Patterns Committee*

OIHA  
State Show

Equitation Over Fences – State Meet

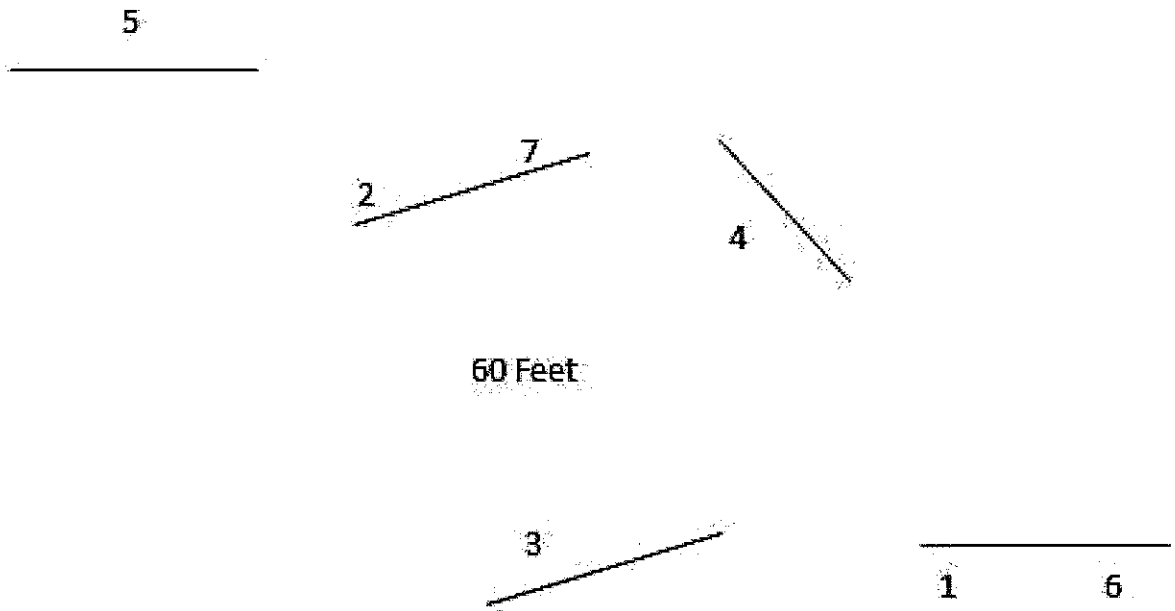

OIHA  
State Show

Trail-State

www.HorseShowPatterns.com

www.HorseShowPatterns.com

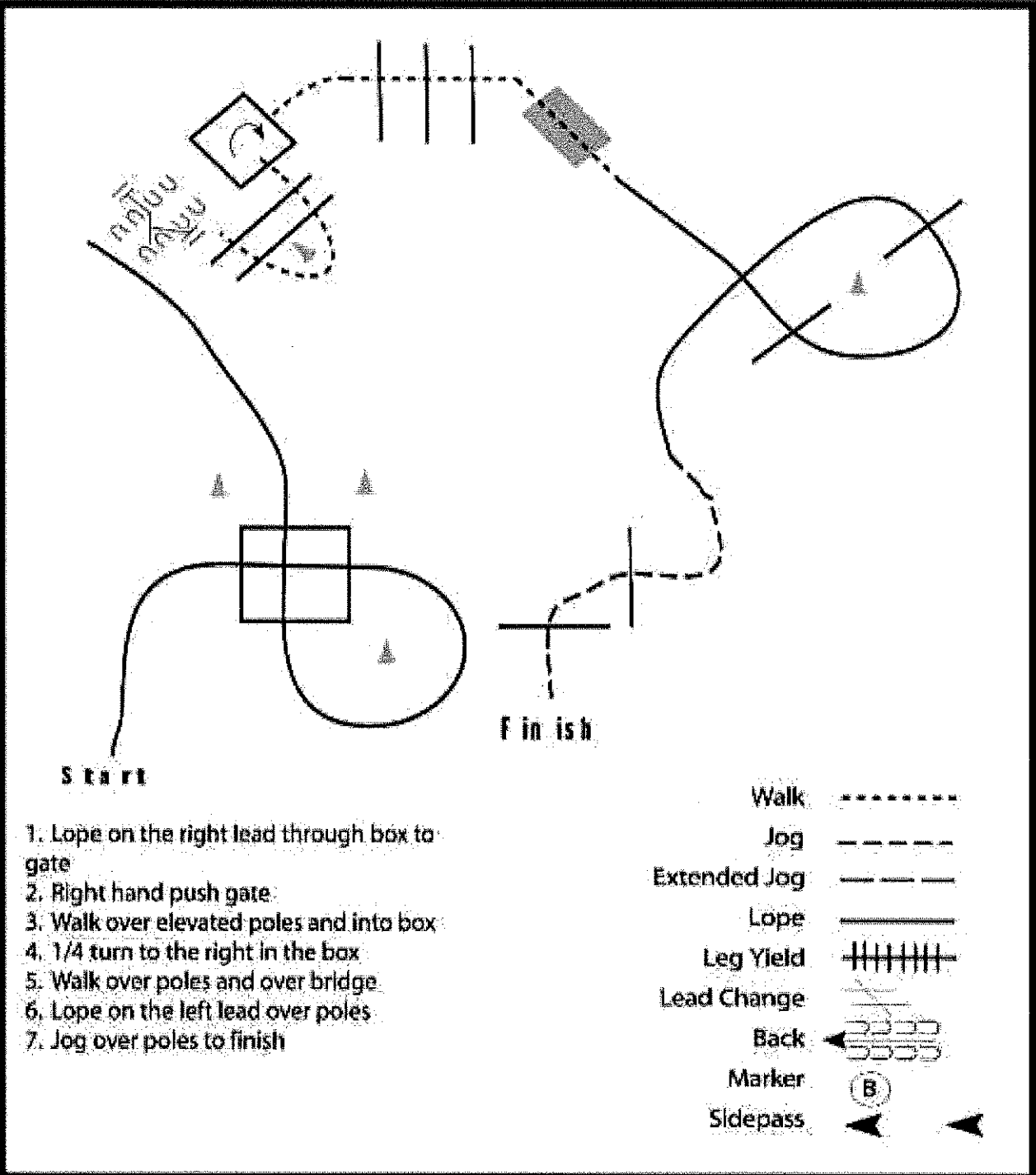

1. Lope on the right lead through box to gate
2. Right hand push gate
3. Walk over elevated poles and into box
4. 1/4 turn to the right in the box
5. Walk over poles and over bridge
6. Lope on the left lead over poles
7. Jog over poles to finish

- Walk .....
  - Jog - - - - -
  - Extended Jog - - - - -
  - Lope \_\_\_\_\_
  - Leg Yield |||||
  - Lead Change / / / / /
  - Back ← ← ← ← ←
  - Marker (B)
  - Sidepass → ▲ → ▲

Pattern Provided by:  
OIHA Pattern Committee

[1/1-11]

## REINING PATTERNS

### Pattern A

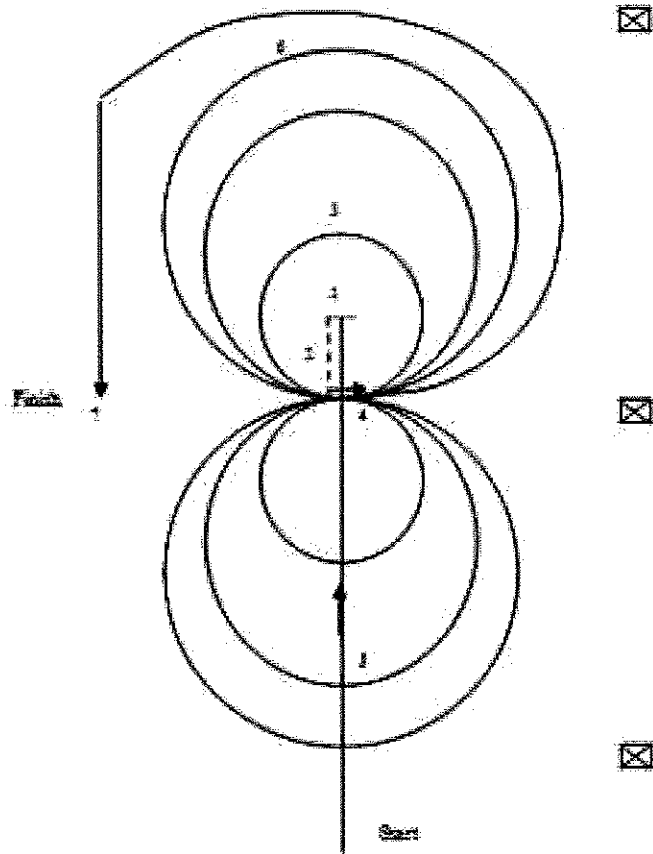

Ride Pattern A as follows:

**Maneuver 1**

Lope in a straight line down the center of the arena past the second cone and stop.

**Maneuver 2**

Back to the center of the pattern, pivot right.

**Maneuver 3**

Lope a large fast circle to the left, then a slow small circle, then a large fast one.

**Maneuver 4**

Do a flying lead change.

**Maneuver 5**

Lope a large fast circle to the right followed by a small slow circle and then another large fast circle.

**Maneuver 6**

Change leads and lope a large fast loop around the end of the circles made to left, straighten your horse, and run down past the center marker.

**Maneuver 7**

Stop; exit the arena.

# OIHA

## Barrel Racing Patterns

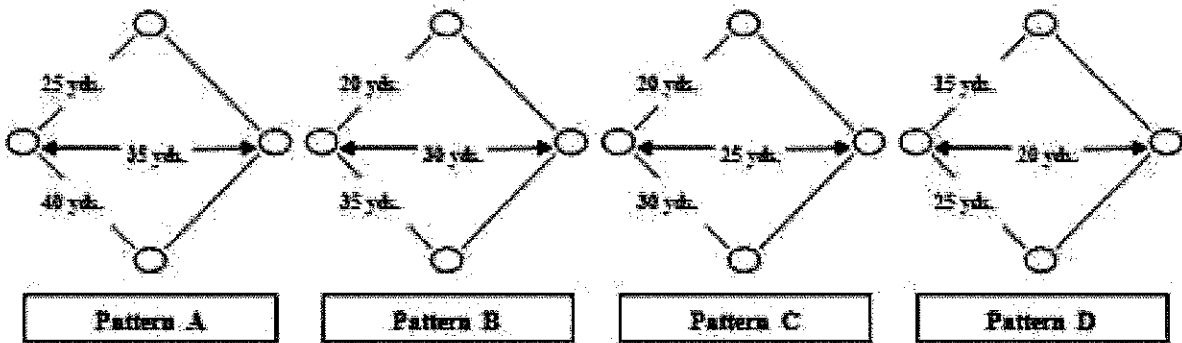
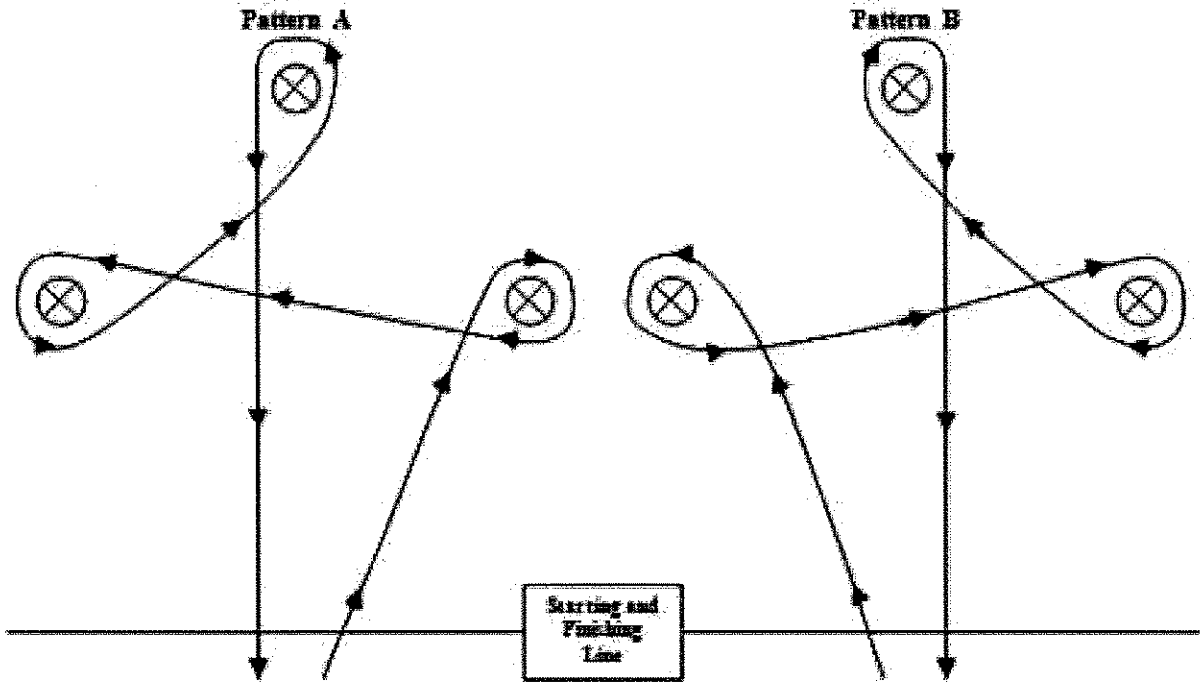



**Pole Bending Patterns**

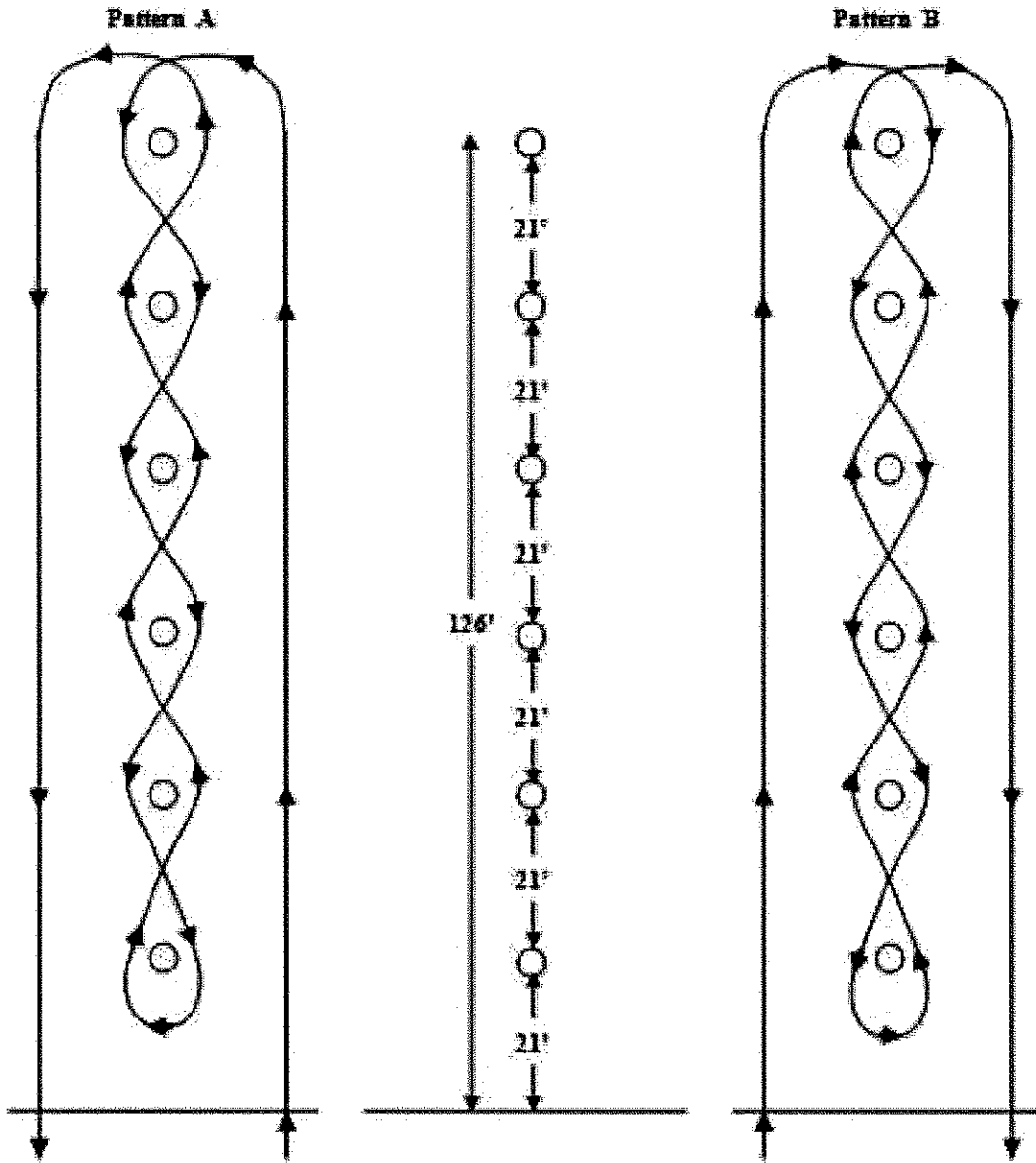

# OIHA

## STAKES RACE

1. Two (2) poles are to be used.
2. The horse & rider run down the right or left side of the poles to the second pole making either a right- or left-hand turn. Exhibitor shall then run to the first pole and make a turn in the opposite direction. Exhibitors then run back to the second pole and repeat first turn then run straight back to start/finish line.
3. Exhibitor shall not cross between two poles before making the first turn or after third turn.
4. Poles knocked over are a disqualification.
5. Failure to do a correct pattern is a disqualification.

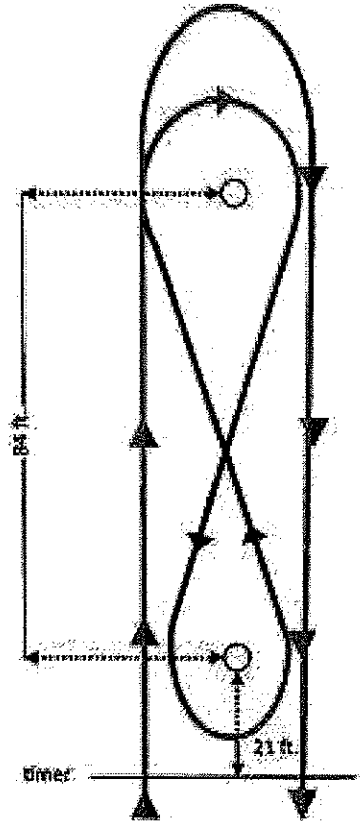
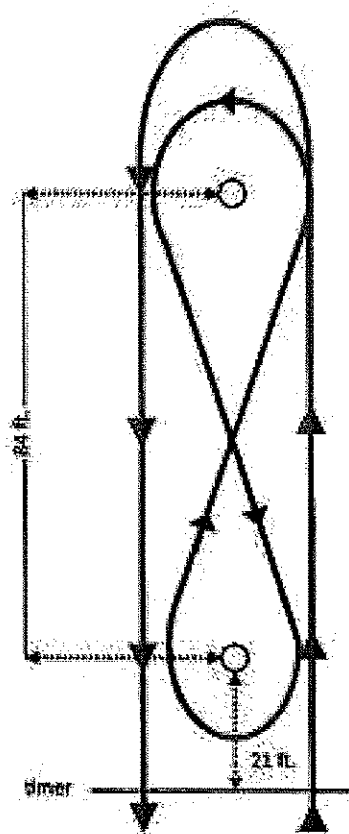

# OIHA

## Two Person Relay Pattern

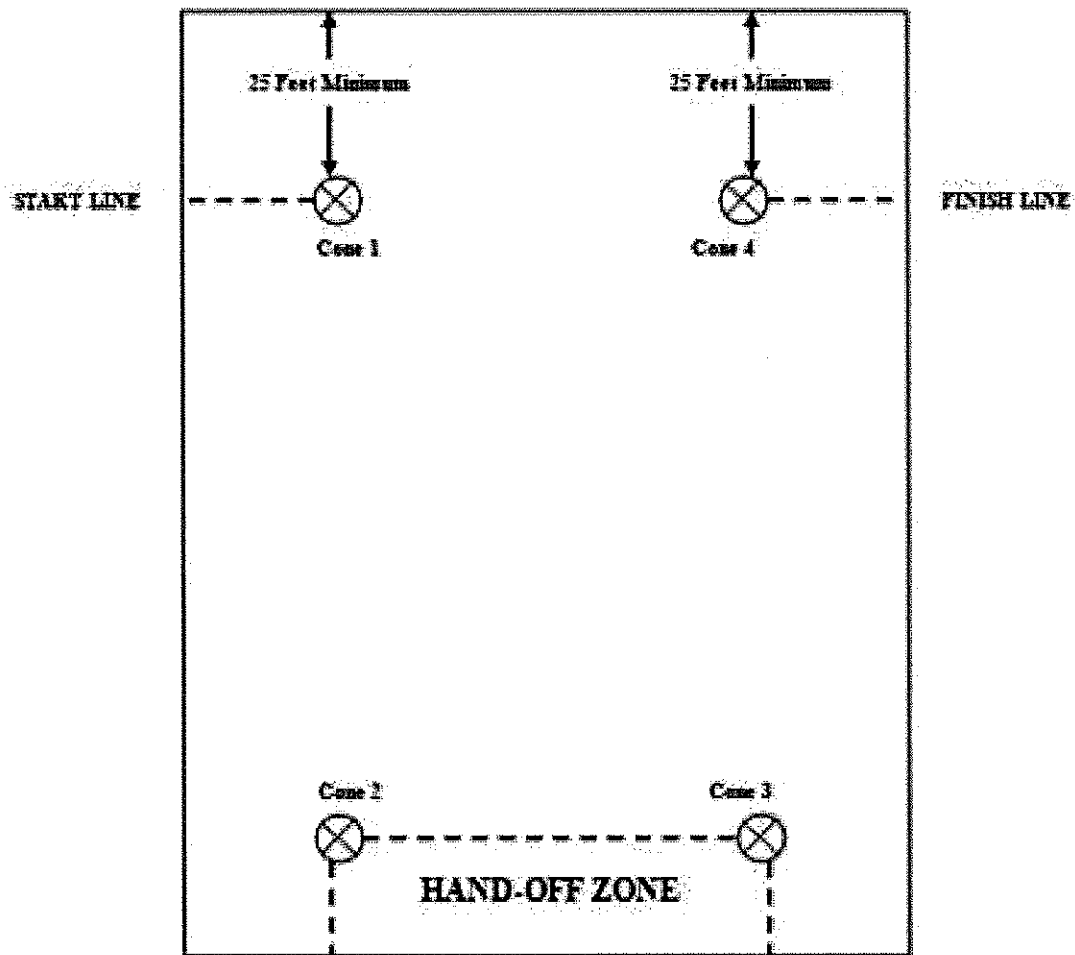

All cones are to be set a minimum of 15 feet off the wall or fence except for the start/finish end which must be set at a minimum of 25 feet off the wall or fence.